



INSTALLATION INSTRUCTIONS

ALUMERO

AS 2.1
CORRUGATED ETERNIT ROOF



ALUMERO GROUP

YOUR BIG ADVANTAGE !

- + in-house consulting and design office
- + competent and reliable staff
- + aluminium mounting profiles and custom-drawn special profiles
- + professional machining
- + overall production, up to the complete assembly from a single source
- + mounting systems for outdoor and rooftop application
- + clamp techniques, laminate and module clamp solutions
- + customized solutions - from design to fabrication and implementation
- + short response times, fast and flexible processing times
- + on time and flexible delivery and logistics concepts

Please read the safety instructions carefully before beginning installation work.

Corrugated eternit roofs are usually implemented as slightly sloping purlin roofs. You should provide a point of anchorage to the substructure at every purlin. Each of these anchoring points is always on a wave crest of the corrugated eternit panel. Generally, the spacing is **approximately 1,15 m**. As the corrugation runs at 90° to the purlins, you have to insert a hanger bolt at every point of intersection between purlin and wave. The mounting profiles are normally mounted from the ridge to the eaves. The modules are thus installed landscape. This does not apply to rafter roofs, as the rafters do not always run beneath a wave. In such cases, you should add an auxiliary rafter to the side of the existing rafter in the proper manner, so as to be able to position the hanger bolt.

You can benefit from ALUMERO's professional and comprehensive consulting service for any further questions. Our experienced engineers and technicians would be glad to be of assistance.

The following torques are to be adhered to:

15 Nm

M8 (A2-70 or A4-70)

30 Nm

M10 (A2-70 or A4-70)

Required tools:



Electric screwdriver

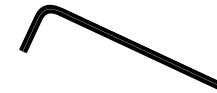

Hexagonal socket wrench (Allen key) **6mm**

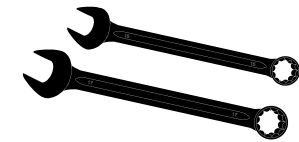

ring / open-ended wrenches (open-ended spanners) **15mm, 17mm**

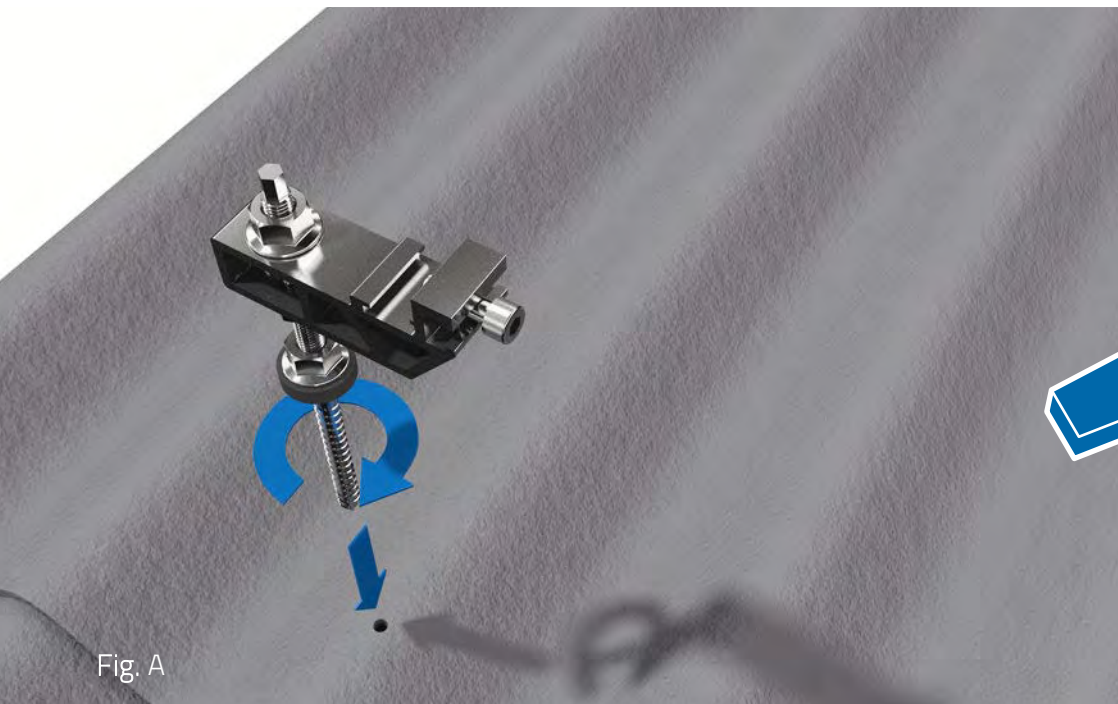

Fig. A



Fig. B

1

Fig. A: At the fastening point, drill a hole into the corrugated eternit roofing and the wooden structure beneath. Make sure that you always select a wave crest as the installation point. For the **M10** hanger bolt, you require a **ø 7 mm** drill bit for the wooden structure, and **ø 13 mm** for the eternit panel. For the **M12** hanger bolt, use a **ø 8 mm** drill bit for the wooden structure, and **ø 15 mm** for the eternit panel. Then screw in the full threaded length of the hanger bolt. Please ensure that you adhere to the minimum anchoring depth of **8 cm (M10)** or **10 cm (M12)** respectively. For anchoring to the support structure, you should provide a distance between the hanger bolt and the edge of the purlin of at least **3 cm (M10)** or **3,6 cm (M12)** respectively.

Once you have placed the hanger bolt, affix the EPDM sealing over the drilled hole with an M10/M12 fixing nut. Then, install the fast mounting plate between 2 additional nuts in such a manner, that a plane bearing surface for the mounting profiles is created, on which the mounting profiles can be placed stressless. Now fix the fast mounting plate by adjusting the two nuts at the head of the hanger bolt connection.



Hint: It is strictly forbidden to install a PV system on an asbestos cement roof.

2

Fig. B: Insert the mounting profile in the preassembled fast mounting plate on the hanger bolt and align the mounting profiles. Afterwards tighten the allen screw to fix the connection.

Please note:

- » Each mounting profile has to be fixed on **minimum two roof fixation elements** (e.g. hanger bolt).
- » The maximum mounting profile length should not exceed **15,0 m**.
- » After **15,0 m**, install an expansion joint of at least **5 cm**.
- » The mounting profiles should have a **maximum cantilever of 30 cm** beyond the last roof fixation element.

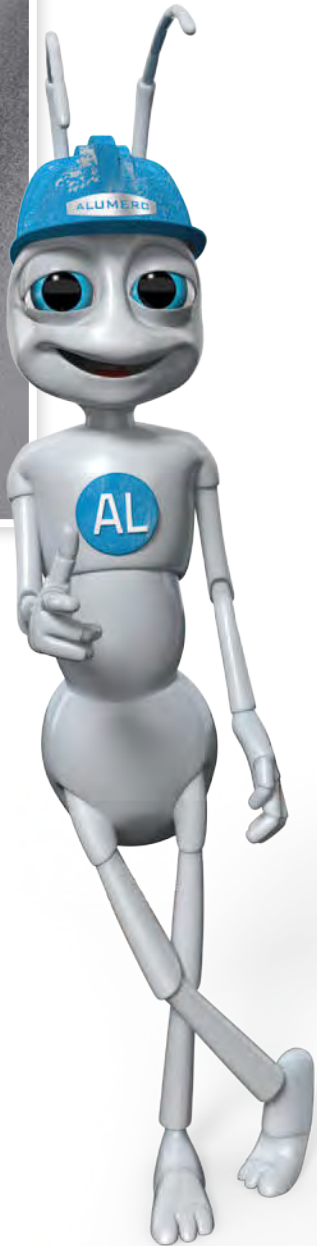

3

Fig. C: To connect the mounting profiles insert the profile connector into the profiles. The mounting profiles should not be plugged together before they are at the installation site (e.g. the roof).



Fig. C



Please note: The connected mounting profiles should not be transported in vertical.

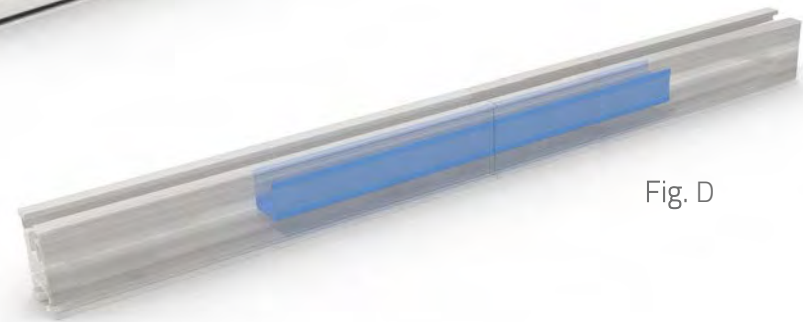

Fig. D

4

Fig. E: End caps can be applied to the mounting profiles as optical finishing. Press them by hand in the end of the mounting profile at the required profile.

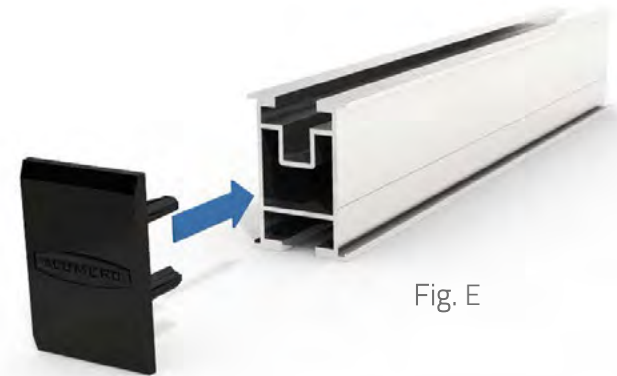

Fig. E

5

Additional information for double-layer systems: Mount the basis layer profiles according to the before mentioned installation steps on the roof fixation elements (e.g. hanger bolts). The orientation of the profiles could be horizontal (parallel to the ridge) as well as vertical (parallel to the rafter).

Fig. F: Screw in the cross connector in the upper slot of the basis layer profile and screw in also the allen screw with the threaded plate in the upper slot.

Fig. G: Align the cross connector and tighten the allen screw to fix it.

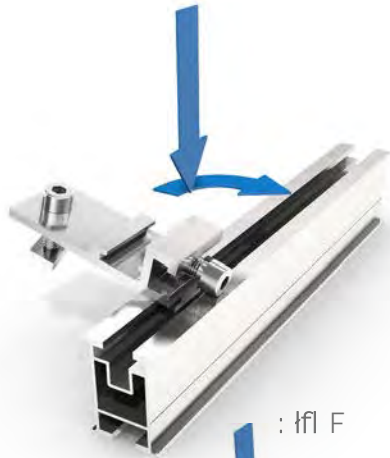

: |f| F

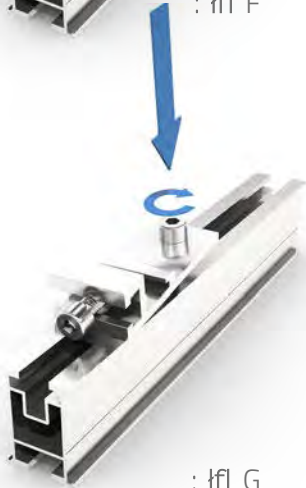

: |f| G

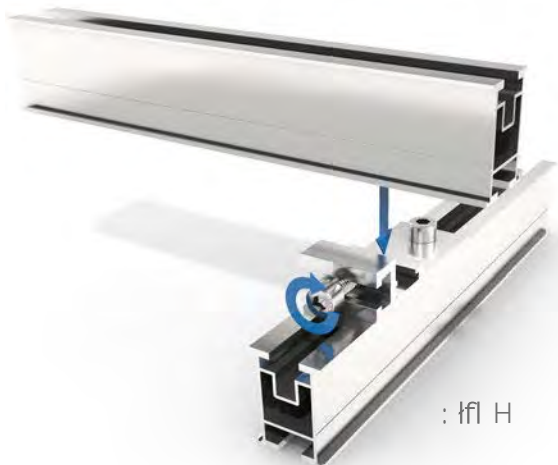

: |f| H

6

Fig. H: Insert the mounting profile in the cross connector and align the mounting profiles. Afterwards tighten the allen screw to fix the connection.

!

Please note: The screw of the cross connector to fix the mounting profile should always be aligned in direction to the top (in direction to the ridge).



7

Fig. I: Place the first module with an edge distance of minimum 3 cm on the mounting profiles. Insert the preassembled end clamps and tighten the allen screws.

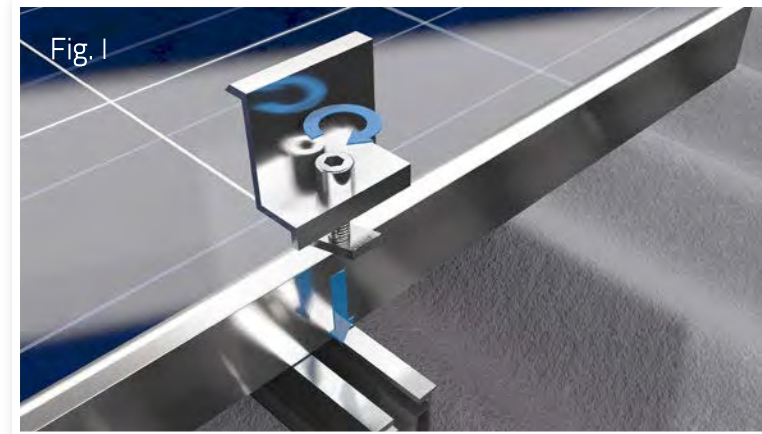

8

Fig. J: For the fixation of the module on the other side, place another module on the mounting profiles beside the first and insert the preassembled middle clamps in between of the two modules. Align the modules and tighten the allen screws to fix them. Proceed in this manner until you have placed the last module of the row. Fix it with end clamps as described before.

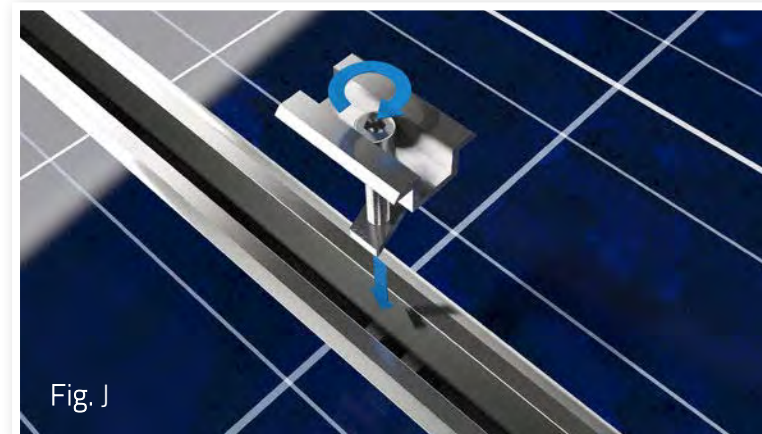

Please note: The mounting areas prescribed by the manufacturer of your module can be found in the module data sheet.



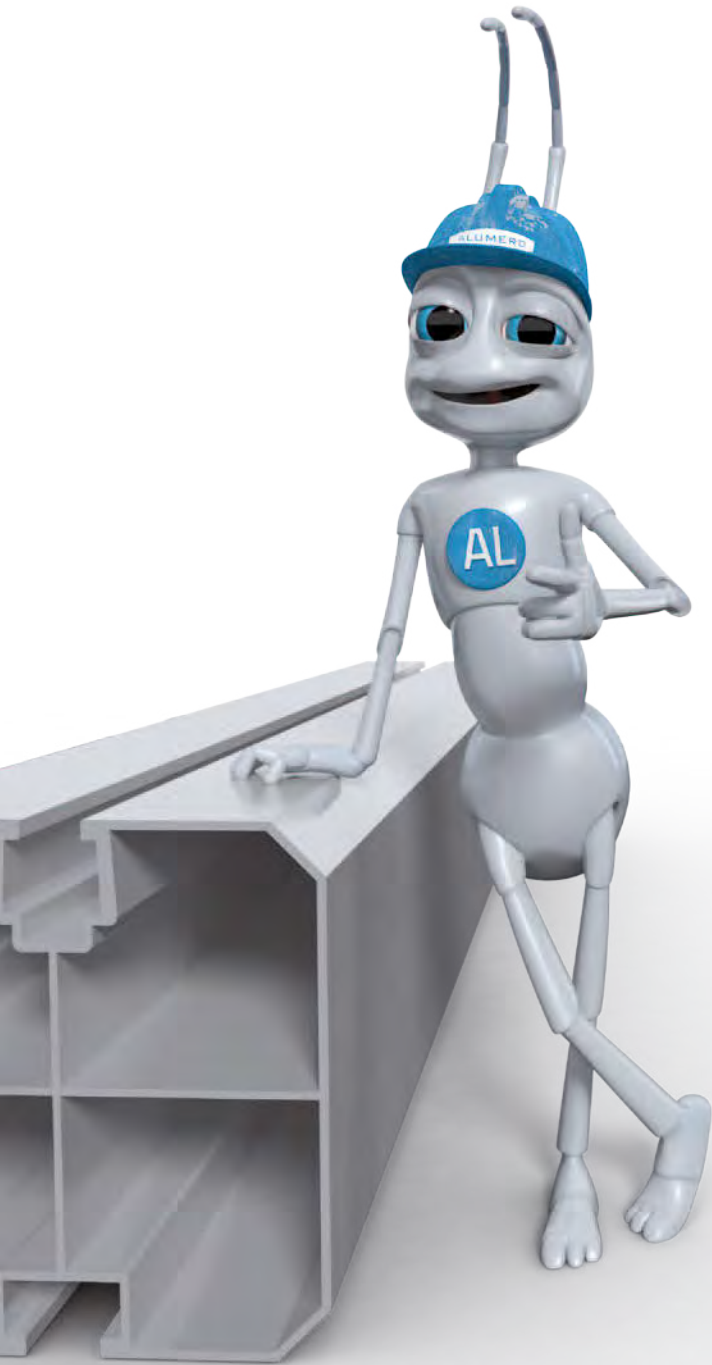

PLEASE PAY ATTENTION TO THE FOLLOWING NOTES !

We recommend, that you read the following information carefully, as it is of great importance when handling the product. Please also inform yourself of the safety regulations which pertain to the other system components.

SAFETY INFORMATION AND WARNINGS

You should adhere to these instructions precisely, whenever working on the PV system. Installation, commissioning, maintenance and repairs may only be performed by appropriately qualified and authorized persons.

Please observe the applicable regulations and safety instructions.

You must observe the following accident prevention regulations:

- » BGV A 1 – General regulations
- » BGV A 2 – Electrical systems and equipment
- » BGV C 22 – Construction work (personal fall protection equipment)
- » The trade association health and safety at work rules (BGR 203 – Working on roofs) and DIN EN 516 „Equipment for accessing roofs“
- » The trade association regulations regarding work clothing and work safety

You must adhere to the following DIN standards:

- » DIN 18299 – General rules for all kinds of building works
- » DIN 18338 – Roof covering and roof sealing works
- » DIN 18360 – Metal construction and locksmith works
- » DIN 4102 – Fire behaviour of building materials and building components

Only authorized personnel may carry out work on systems of Alumero Systematic Solutions GmbH. The operator of the system has the following safety-related obligations:

- » Performance of regular annual maintenance work, e.g. inspection of cabling, bolt connections, and the roof skin.
- » The mounting system may only be installed by persons with suitable qualifications, technical skills, and knowledge of the fundamentals of mechanics.
- » It must be ensured that the assigned persons can assess the work allocated to them, and can identify possible dangers.
- » The installation instructions are part of the product, and must be available during installation.
- » It must be guaranteed that the installation instructions, and particularly the safety instructions, have been read and understood by the assigned personnel before installation.
- » The trade association regulations, the local work safety regulations and the technical regulations must be adhered to.
- » Suitable hoisting equipment and ladders are to be used for the installation work. No leaning ladders may be used.
- » It is necessary to arrange for a qualified construction engineer to assess the building's existing static loading characteristics with regard to the additional loads of a PV system.
- » Any general load reduction measures specified by Alumero Systematic Solutions GmbH (e.g. the need to clear snow, so as to limit the snow load) are to be observed.

WARRANTY / PRODUCT LIABILITY (EXCLUSION)

The dimensioning information included in these instructions merely represents information gathered in practice. Binding structural calculations for the mounting system can be calculated with the software Alumero.Solar.Pro.Tool.

As the installation company, you are responsible for correct execution of installation work. Alumero Systematic Solutions GmbH is not liable for the dimensioning information included in commercial system proposals.

As installer, you are responsible for the mechanical durability of the interface connections mounted on the building's structure. In particular, this includes that these are leak-tight. The components of Alumero Systematic Solutions GmbH are designed for the expected loads and they are in compliance with the effective state of the art.

For this purpose, you have to specify in writing all general technical framework conditions in the project documentation form (information on the support structure, snow load zone, building heights, wind loads, etc.) when requesting information/ordering from Alumero Systematic Solutions GmbH.

Alumero Systematic Solutions GmbH is not liable for incorrect handling of the installed parts.

Any use close to the sea is excluded because of the increased risk of corrosion.

Alumero Systematic Solutions GmbH grants a 2-year product guarantee on the service life and stability of the mounting systems, subject to correct handling, dimensioning in accordance with the static loading conditions, normal environmental conditions, and normal ambient conditions. This applies within the generally prevalent weather conditions and environmental conditions.

Material and workmanship guarantee:

Alumero Systematic Solutions GmbH grants a 10-year material and workmanship guarantee on the materials used. Consult the specific guarantee conditions for more detailed information.

NOTES ON ELECTRICAL INSTALLATION WORK

Only if you are a qualified electrician, you may perform any electrical work. The applicable DIN standards, VDE regulations, VDEW guidelines, VDN guidelines, accident prevention regulations and the regulations of the local utility company are authoritative in this regard.

- » DIN VDE 0100 (Installation of high voltage systems with nominal voltages up to 1000 V)
- » VDEW guideline for parallel operation of domestic power-generation systems with the low voltage grid of the utility company
- » VDI 6012 sheet 2, guideline for decentralized energy systems in buildings: Photovoltaics
- » Leaflet for VDEW guideline „Domestic power-generation systems on the low voltage grid“
- » VDN guideline „Domestic power-generation systems on the low voltage grid“
- » DIN/VDE regulations, DIN/VDE 0100 „Installing high voltage systems with grid voltages up to 1000 V“, in particular VDE 0100, Part 410, „Protection against direct and indirect contact (Direct current > 120 V, < 1000 V direct current)“ and the „Accident prevention regulations of the commercial trade associations“ VBG4 „Electrical systems and equipment“
- » DIN VDE 0100-540 Selection and installation – Earthing, protective conductors and equipotential bonding conductors
- » DIN 57185 VDE 0185 Installation of a lightning protection system and VDS 2010

IMPORTANT WARNINGS

Solar modules generate electricity as soon as they are exposed to light. There is always a voltage present. The fully insulated plug contacts provide a level of contact protection but when dealing with solar modules, the following points must be observed:

- » Do not insert electrically conductive parts into the plugs or sockets.
- » Do not install solar modules and wiring using wet plugs or sockets.
- » Perform any work on cabling with extreme caution.
- » Do not carry out any electrical installation work in damp conditions.
- » Also with low lighting, very high direct voltages arise at the series connection of modules, which can be life-threatening upon contact. In particular, note the possibility of secondary damage in the event of electric shocks.

Even when the unit is switched off, high contact voltages may still be present inside the inverter:

- » Be particularly careful when working on the inverter and the cables.
- » After switching off the inverter, it is essential to wait for the time interval specified by the manufacturer before beginning any further work to allow the high voltage components to discharge.
- » Please also observe the installation guidelines provided by the inverter manufacturer.

When breaking a connected string of modules (e.g. when disconnecting the DC line from the inverter under load), a lethally strong electric arc can occur:

- » Never disconnect the solar generator from the inverter as long as it is connected to the mains.

NOTES ON THE INSTALLATION OF MOUNTING SYSTEMS

For installation in roof areas, you must adhere to the currently applicable structural engineering regulations, especially the requirements set out in the DIN standards and in the „Regulations of the German Roofing Industry“ („Regelwerk des Deutschen Dachdeckerhandwerks“).

- » Check to see if all screw connections are tightened correctly.
- » Adhere to the specified torques.
- » Regardless a verifiable static equilibrium, it is your responsibility to ensure before every installation that the product meets the local static requirements pursuant to DIN 1055.
- » DIN standard 1055 „Actions on structures“
 - Part 1: Densities and weights of building materials, structural elements, stored materials
 - Part 4: Wind loads
 - Part 5: Snow load and ice load
 - Part 100: Basis of structural design – Safety concept and design rules
- » The mounting system is designed in accordance with DIN 4113 “Aluminum constructions under predominantly static loading” and DIN 18800 “Steel structures; design and construction” or the corresponding Eurocode EC1, EC3, EC9.
- » Ensure that the substructure, support structure and other affected layers (such as an insulation layer) have adequate load capacity (based on dimensions, condition and suitable material properties).
- » Make sure that the rainwater runoff is not impeded.
- » Pay attention to the physical construction aspects (e.g. possible condensation problems caused by penetration of insulating layers).

STANDARDS AND GUIDELINES

All of the standards and guidelines listed here are published for and applicable to Germany. They are to be complied with in their current version. Outside of Germany, please also observe the corresponding national standards and guidelines.

PRODUCT LIABILITY

The technical documentation constitutes part of the product. Alumero Systematic Solutions GmbH is not liable for damages caused by noncompliance with the installation instructions, particularly the safety instructions, or caused by inappropriate use of the products.

WWW.ALUMERO.AT

CONTACT HEADQUARTER

Alumero Systematic Solutions GmbH
Sonnenweg 1-2
5164 Seeham - Österreich
T +43 6217 / 68 41-0
F +43 6217 / 68 41-41
alumero@alumero.at
www.alumero.at

CONGRATULATIONS,
WELL DONE !

